

## Moderner Landhausstil 3-Liter-SchwörerHaus Plan 481.1



 **Schwörer  
Haus**® KG

Hans-Schwörer-Straße 8  
72531 Hohenstein-Oberstetten  
Telefon 073 87/16-0  
Telefax 073 87/16-238

[www.schworer.de](http://www.schworer.de)  
[info@schworer.de](mailto:info@schworer.de)

Roßlauer Straße 68  
06869 Coswig  
Telefon 03 49 03/42-200  
Telefax 03 49 03/42-240

Hafenstraße 12  
56575 Weißenthurm  
Telefon 0 26 37/914-0  
Telefax 0 26 37/914-100

 **Schwörer  
Haus**® KG  
**DIE ZUKUNFTSHÄUSER**

Schwörer Musterhauszentrum  
72531 Hohenstein-Oberstetten  
Tel. 073 87/16-314, Fax 073 87/16-109

3-Liter-SchwörerHaus Plan 481.1: Dicke Dämmpakete in Außenwand und Dach, wärmegeämmte Kellerdecke, 3-fach verglaste Hightech-Fenster, Frischluft-WärmeGewinnTechnik, patentierte Synergietechnik (Winddichtheit), Wärmepumpe, Thermosolar- und Photovoltaikanlage

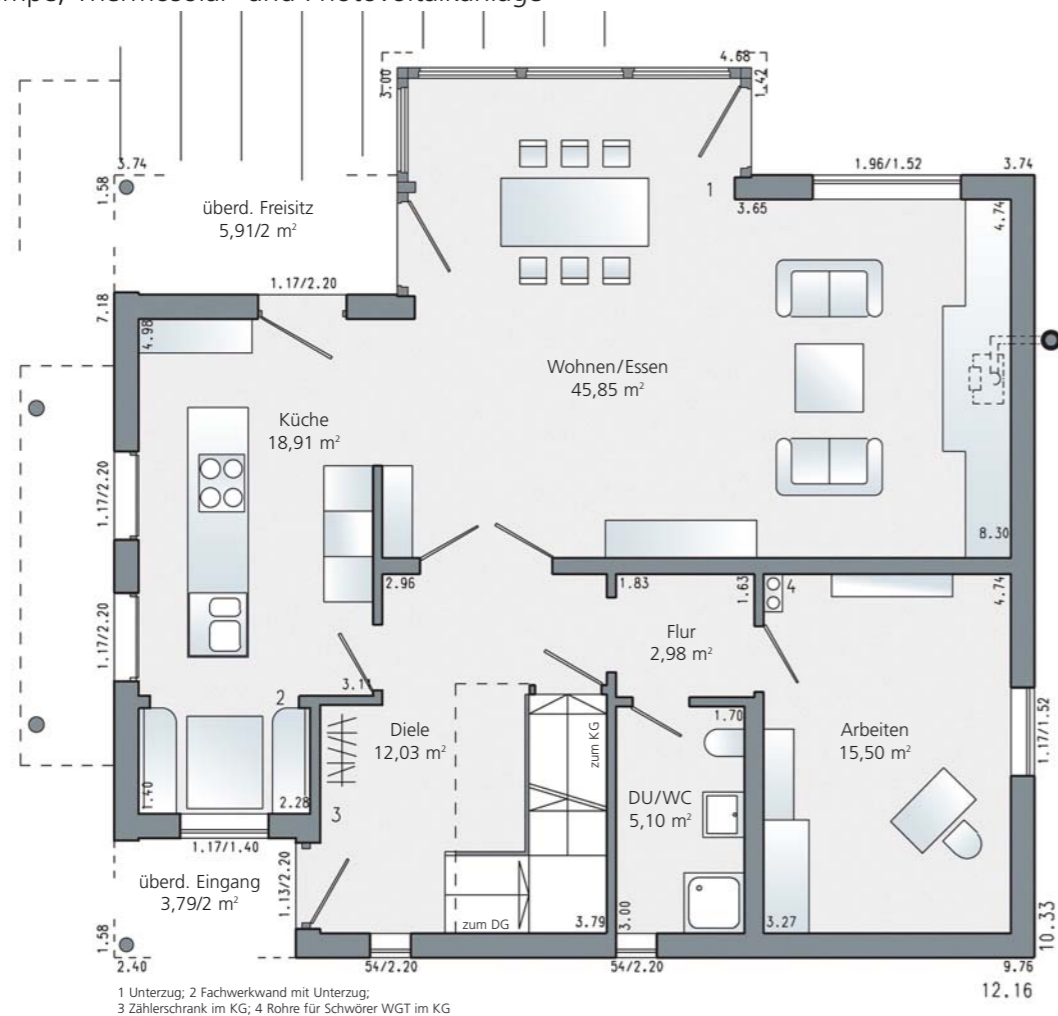

**Erdgeschoss Plan 481.1**  
105,22 m² Wohnfläche  
Maßstab 1:100

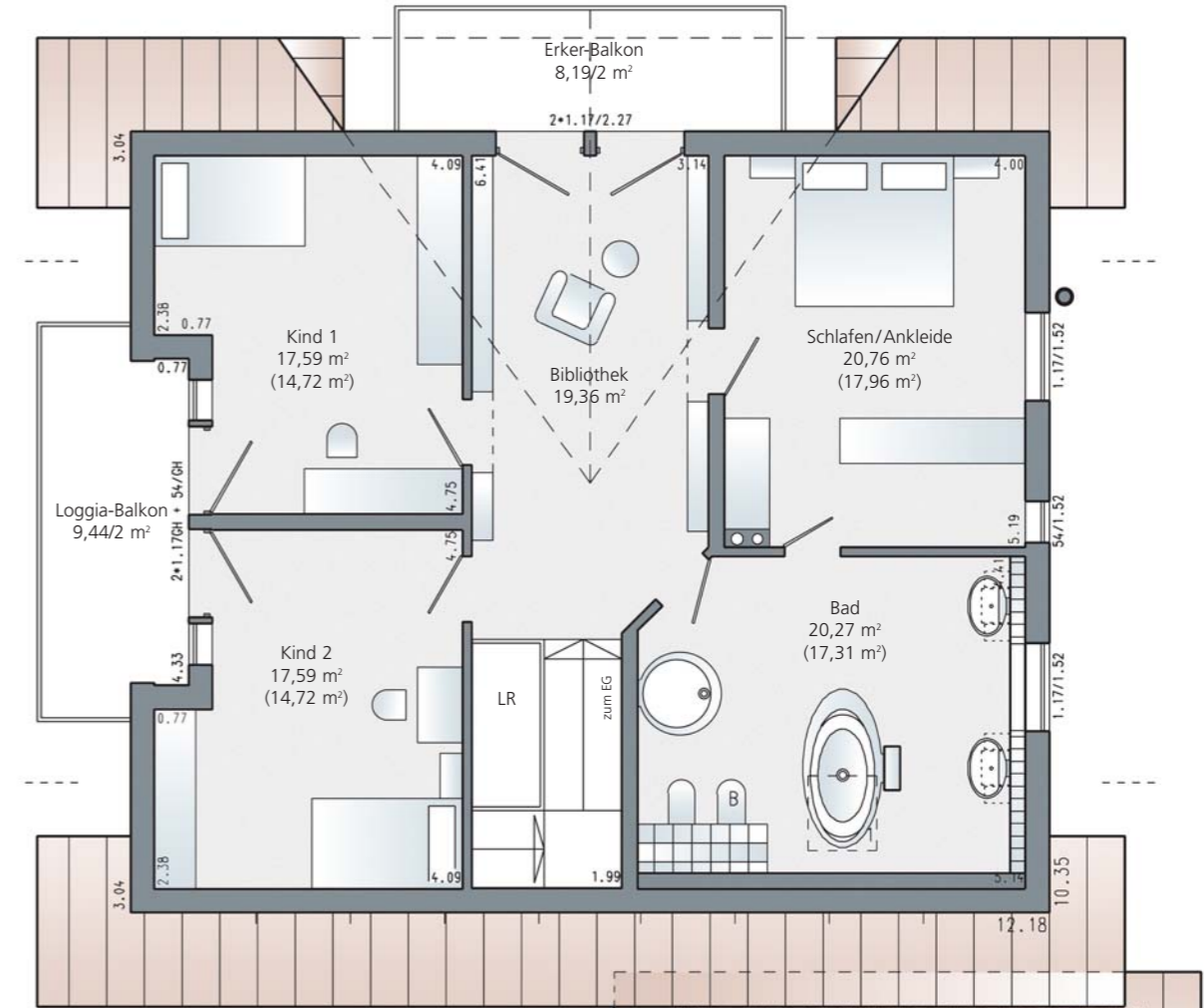
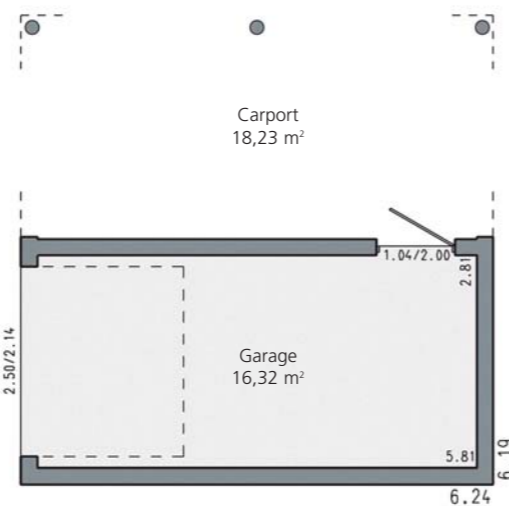

**Dachgeschoss Plan 481.1**  
DN 35°, KN 105 cm  
104,39 m² nutzbare Grundfläche  
92,89 m² Wohnfläche  
Maßstab 1:100

